



Plano de trabalho em inox.  
Plano de trabajo inoxidable rigidizado.  
Stainless steel stiffened working-table.  
Plan de travail Inox rigidisé.  
Arbeitsplatte aus versteiftem Edelstahl.



Plano inox porta máquina cortadora.  
Plano inoxidable porta-cortador.  
Stainless steel table for slicer.  
Tablette inox de support machine à trancher.  
Edelstahl Auflagebrett für Aufschnittmaschine.



Plano porta balança.  
Tablette porta-balança.  
Scale-holder.  
Tablette porte-balance.  
Waagbrett.



Plano em polietileno para corte de alimentos.  
Tajo de políteno para alimentos.  
Cutting board in food-safe polythene.  
Planche de coupe en polythène alimentaire.  
Schneidbrett aus Polythen.



Dispensador de sacos.  
Bac porte-sachets.  
Bag dispenser.  
Cubeta porta-polsas.  
Beutelwanne.



Estantes inoxidáveis de 2 níveis.  
Etagères inox à 2 niveaux.  
2-step stainless steel shelves.  
Estantes inoxidable a 2 niveles.  
Edelstahlablagen auf 2 Stufen.



Prato promocional intermédio.  
Plato promocional intermedio.  
Intermediate promotional plate.  
Plateau promotionnel intermédiaire.  
Zwischenplatte für Sonderangebote.



Prato promocional.  
Plato promocional cuba.  
Promotional plate in basin.  
Plateau promotionnel cuve.  
Sonderangebotsplatte Wanne.



Estante intermédia (individual).  
Estante intermedio corredizo (individual).  
Intermediate sliding shelf (single).  
Etagère intermédiaire coulissante (simple).  
Verschiebbare Zwischenglasablage  
(Einzelausführung).



Porta papéis.  
Porta-papeles.  
Paper holder.  
Porte-papier.  
Papiertasche.



Porta facas.  
Porta-cuchillos.  
Knife holder.  
Porte-couteaux.  
Messerträger.



Portas de correr posteriores.  
Puertas corredizas posteriores.  
Plexiglass sliding door.  
Fermeture postérieure plexi.  
Rückschiebescheiben aus Plexiglas.



Plano para fazer trocos(só em VCB).  
Plato para la devolución de la vuelta (sólo VCB).  
Plexiglass change shelf (VCB only).  
Plateau rend-monnaie en plexi (uniquement VCB).  
Restrückgabeinsel aus Plexiglas (nur VCB).

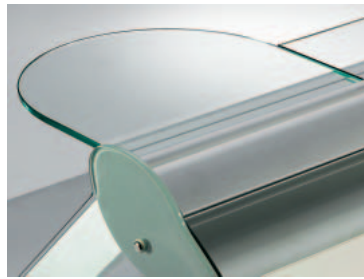

Estante promocional em vidro.  
Estante promocional de cristal.  
Promotional glass shelf.  
Étagère promotionnelle en verre.  
Sonderangebotsablage aus Kristallglas.



Estantes inoxidáveis de 3 níveis.  
Estantes inoxidable a 3 niveles.  
3-step stainless steel shelves.  
Étagères inox à 3 niveaux.  
Edelstahlablagen auf 3 Stufen.



Vão aberto para objectos.  
Vano abierto para objetos.  
Dry storage compartment.  
Réserve sèche ouverte.  
Offenes Ablagefach.



Divisórias em vidro.  
Tabiques cuba de cristal.  
Glass basin dividers.  
Séparation cuve en verre.  
Trenngläser für Wanne aus Kristallglas.



Estante intermédia amovível (Dupla).  
Estante intermedio corredizo (doble).  
Intermediate sliding shelf (double).  
Étagère intermédiaire coulissante (double).  
Verschiebbare Zwischenablage (Doppelausführung).



Estante intermédia em vidro.  
Estante intermedio cristal.  
Intermediate glass shelf.  
Étagère intermédiaire en verre.  
Zwischenkonsole aus Kristallglas.



Grelha para pão.  
Rejilla pan.  
Wire bread shelf.  
Grille de pain.  
Brotgitter.



Terminal.  
Terminal.  
Extension counter.  
Meuble-caisse.  
Anbaumöbel.

fully accessorized





MONDEGO SELF





MONDEGO VCB "ZAMPONI/PEDESTALS"

MONDEGO VCA BT

Mondego	Comprimento sem laterais Largo sin respaldos Length without side-walls Longueur sans joues Länge ohne Seiten	Temperatura de trabalho Temperatura de trabajo Working temperature Temp. de fonctionnement Betriebstemperatur	Superfície exposición hor. Superficie de exposición de apoyo Horizontal display surface Surface d'exposition horizontale Gesamte Ausstellfläche	Capacidade Capacidad útil Net volume Capacité utile Nutzleistung		Peso Peso Weight Poids Gewicht	
	mm		m <sup>2</sup>	vitrina cuba display surface vitrine Auslagefläche	reserva selda storage réserve Unterbau	dm <sup>3</sup>	
						Kg	
						REMOTE	UNIT
VCA	937	+2°C /+4 °C 0°C/+2 °C	0.81	105	95	148	178
	1250		1.08	140	125	193	223
	1562		1.36	175	160	227	255
	1875		1.63	210	190	266	296
	2500		2.17	280	250	336	365
	3125		2.72	350	320	400	432
	3750		3.26	420	380	460	495
	AA4		0.58	75	-	-	-
	AA9		1.16	150	-	-	-
	AC4		0.54	70	-	-	-
AC9	1.08	140	-	-	-		
VCA MAXI	937	+2°C /+4 °C 0°C/+2 °C	0.81	210			
	1250		1.08	280			
	1562		1.36	350			
	1875		1.63	420			
	2500		2.17	560			
	3125		2.72	700			
	3750		3.26	840			
	AA4		0.58	150			
	AA9		1.16	300			
	AC4		0.54	140			
AC9	1.08	280					
SELF	937	+2°C /+4 °C 0°C/+2 °C	0.81	105	95	105	124
	1250		1.08	140	125	140	165
	1562		1.36	175	160	175	207
	1875		1.63	210	190	210	248
	2500		2.17	280	250	280	330
	3125		2.72	350	320	350	413
	3750		3.26	420	380	420	495
	AA4		0.58	75	-	-	-
	AA9		1.16	150	-	-	-
	AC4		0.54	70	-	-	-
AC9	1.08	140	-	-	-		
SELF MAXI	937	+2°C /+4 °C 0°C/+2 °C	0.81	210			
	1250		1.08	280			
	1562		1.36	350			
	1875		1.63	420			
	2500		2.17	560			
	3125		2.72	700			
	3750		3.26	840			
	AA4		0.58	150			
	AA9		1.16	300			
	AC4		0.54	140			
AC9	1.08	280					
VCB	937	+2°C /+4 °C 0°C/+2 °C	0.81	105	95		
	1250		1.08	140	125		
	1562		1.36	175	160		
	1875		1.63	210	190		
	2500		2.17	280	250		
	3125		2.72	350	320		
	3750		3.26	420	380		
	AA4		0.58	75	-		
	AA9		1.16	150	-		
	AC4		0.54	70	-		
AC9	1.08	140	-				
VCB MAXI	937	+2°C /+4 °C 0°C/+2 °C	0.81	210			
	1250		1.08	280			
	1562		1.36	350			
	1875		1.63	420			
	2500		2.17	560			
	3125		2.72	700			
	3750		3.26	840			
	AA4		0.58	150			
	AA9		1.16	300			
	AC4		0.54	140			
AC9	1.08	280					

EN 441

Clase climática ambiental  
Clase climática ambiental  
Classe climatique  
Raumklimaklasse  
Environmental climatic class

3

+25°C 60% U.R.

Modelos e características técnicas sujeitos a alteração sem aviso previo. • Modelos y características técnicas sujetos a variaciones sin previo. • Models and characteristics subject to change without notice. • Modèles et caractéristiques peuvent varier sans préavis. • Änderung von technischen Daten ohne vorherige Benachrichtigung vorbehalten.

Mondego	Comprimento sem laterais Largo sin respaldos Length without side-walls Longueur sans joues Länge ohne Seiten	Temperatura de trabalho Temperatura de trabajo Working temperature Temp. de fonctionnement Betriebstemperatur	Superfície de exposição hor. Superficie de exposición de apoyo Horizontal display surface Surface d'exposition horizontale Gesamte Ausstellefläche	Capacidade Capacidad útil Net volume Capacité utile Nutzleistung		Peso Peso Weight Poids Gewicht	
	mm		m <sup>2</sup>	vitrina cuba display surface vitrine Auslagefläche	reserva selda storage réserve Unterbau	dm <sup>3</sup>	
						Kg	
						REMOTE	UNIT
VCA PANE	937	ambiente/ambient	0.71	173		-	-
	1250		0.95	230			
	1562		1.18	288			
	1875		1.42	345			
	2500		1.89	460			
	3125		2.37	575			
	3750		2.84	690			
VCB PANE	937	ambiente/ambient	0.71	173		-	-
	1250		0.95	230			
	1562		1.18	288			
	1875		1.42	345			
	2500		1.89	460			
	3125		2.37	575			
	3750		2.84	690			
VCA FISH	937	+2°C/+4°C	0.74	75		-	-
	1250		0.99	100			
	1562		1.23	125			
	1875		1.48	150			
	2500		1.97	200			
	3125		2.47	250			
	3750		2.96	300			
VCB FISH	937	+2°C/+4°C	0.74	75		-	-
	1250		0.99	100			
	1562		1.23	125			
	1875		1.48	150			
	2500		1.97	200			
	3125		2.47	250			
	3750		2.96	300			
VCA BT	1250	-18°C/-25°C	1.10	275		-	-
	1875		1.65	412			
VCA TCBM	937	+65°C	0.80	57		-	-
	1250		1.04	79			
VCA TCPW	937	+65°C	0.80	57		-	-
	1250		1.04	79			
EN 441	Clase climática ambiental Clase climática ambiental Classe climatique Raumklimaklasse Environmental climatic class		3	+25°C	60% U.R.		

Modelos e características técnicas sujeitos a alteração sem aviso previo. • Modelos y características técnicas sujetos a variaciones sin preaviso. • Models and characteristics subject to change without notice. • Modèles et caractéristiques peuvent varier sans préavis. • Änderung von technischen Daten ohne vorherige Benachrichtigung vorbehalten.



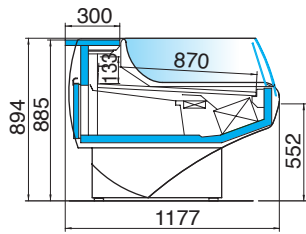

MONDEGO SELF

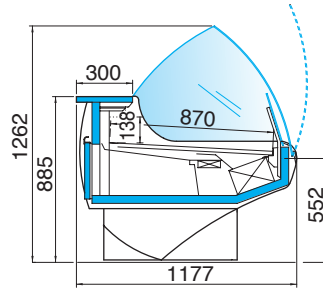

MONDEGO VCB

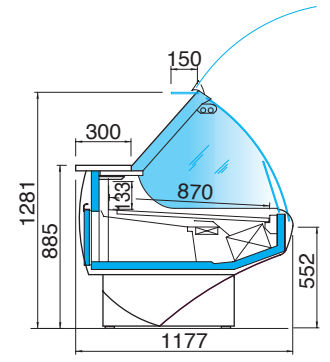

MONDEGO VCA

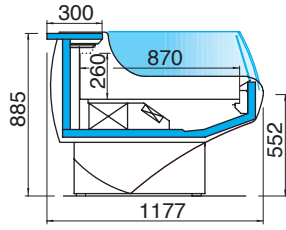

MONDEGO SELF MAXI

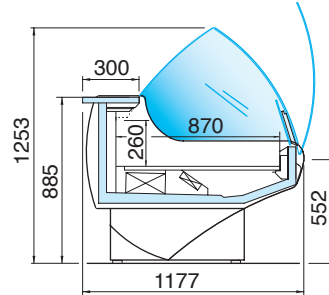

MONDEGO VCB MAXI

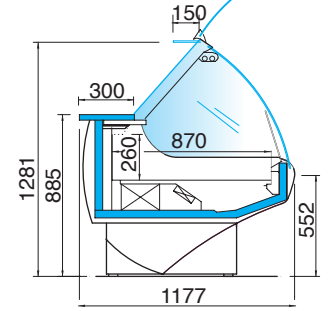

MONDEGO VCA MAXI

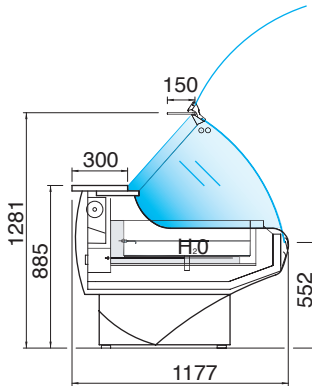

MONDEGO TCBM

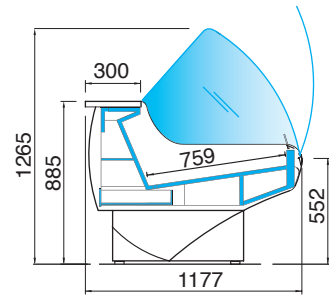

MONDEGO VCB PANE

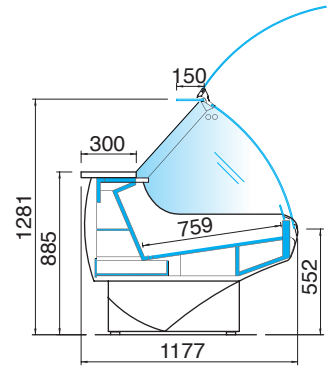

MONDEGO VCA PANE

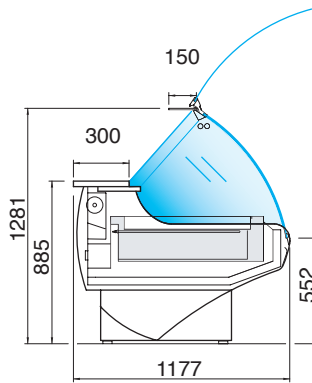

MONDEGO TCPW

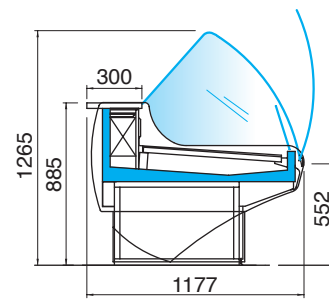

MONDEGO VCB FISH

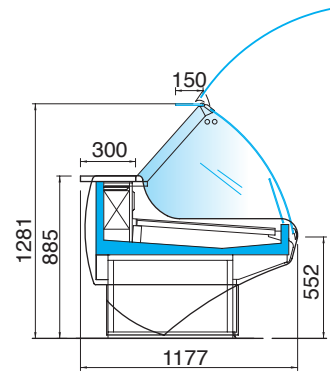

MONDEGO VCA FISH

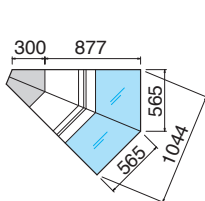

AA4

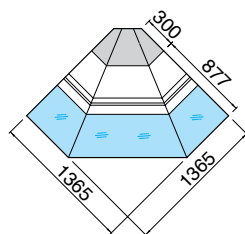

AA9

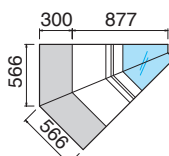

AC4

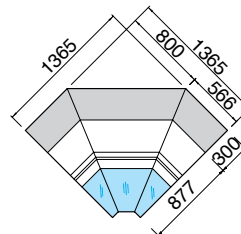

AC9

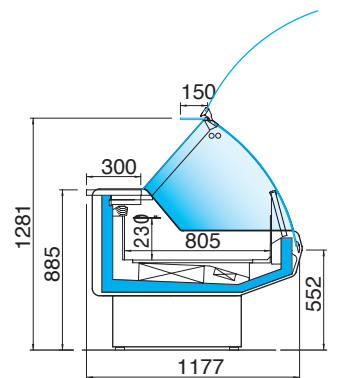

MONDEGO VCA BT



RAL 1018



RAL 1006



RAL 3000



RAL 6016



RAL 6017



RAL 5012



RAL 5002

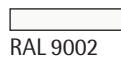

RAL 9002



RAL 7037

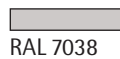

RAL 7038



Estrada Nacional N.9  
RAL - 2710 Sintra Portugal  
Tel. +351 21-9608660  
Fax +351 21-9616046  
Internet: [www.arneg.pt](http://www.arneg.pt)  
E-Mail: [arneg@arneg.pt](mailto:arneg@arneg.pt)

